

The wireless Opal RFX external passive infrared intruder detector design to detect and transmit reliable event based triggers to the weatherproof RFX-3 Receiver. These combined units enable the simultaneous or individual control of cameras, VCR's, DVR's and virtually all low-voltage switching requirements.

The weatherproof receiver with front and rear tamper output can be positioned in line of sight up to 150m away. The active state of up to 3 Opal RFX PIR's is constantly monitored. These signals are directed to their respective volt free outputs and in addition there are a further eight individual monitoring and information outputs.

The RFX-3 Receiver monitors the active state of up to three Opal RFX passive infra red detectors.

The RFX-3 Receiver can be mounted externally or internally. The transmission distance of 150m can be obtained if the detectors are in true line of sight to the receiver. When installing the RFX-3 Receiver internally, the transmission distance of 150m will be reduced depending on the thickness and type of material structure the radio signals have to pass through or around. It is advisable to conduct an RF continuity test when mounting the receiver internally to ensure that the radio signals can be received in the desired locations. (RF continuity test page 3).

WIRELESS TRANSMISSION

Each detector transmits radio signals to the receiver and has over 16.7 million individual codes. The receiver only responds to the transmitter that has been linked to a channel to identify it.

The receiver can only analyse this information after the individual code has been transferred via the secure wire code learning link. This transfer is only required on the initial setup, any subsequent changes to the detector programming will be relayed by radio automatically to the receiver. (programming chart - page 3).

FEATURES

1. Secure wire code transfer connector
2. Power supply input
3. LO- output pulses every 5 seconds when any batteries are low
4. 3 x 'A' -ve outputs which activate for -.4 seconds on detection (24hour)
5. 'S' output - photocell controlled
6. 3 x RF- loss of active signal outputs. Activates 5 mins. after not receiving a signal from a registered detector.
7. 3 x independent volt free CCTV contacts. Adjustable 0.4 to 60 seconds.
8. Selection jumper - Normally open or normally closed CCTV contacts
9. 3 x RF loss of signal LED indicators
10. 10. Reception - gives indication of the radio signal being received.

(a) Flicker =normal

(b) On and off indicates conflict with other radio equipment on the same frequency in close proximity.

11. 3 x Channel buttons

For us in code transfer function only.

Plus detection indicator that light for the length of the CCTV timer setting.

12. Battery low indicator corresponding detection indicator will also flash every 5 second when battery is low (see 3).

13. Tamper will activate/
(a) when cover removed or
(b) displacing from the mounting point

14. Aerial

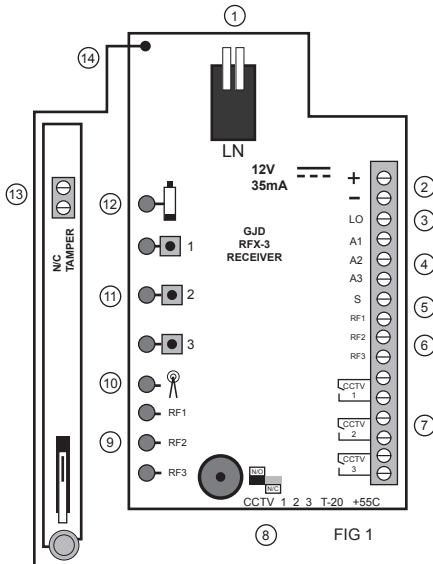
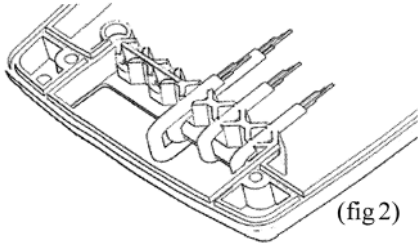

FIG 1

RFX-3 RECEIVER INSTALLATION

The receiver has five cable inlets which have individual moisture and insect blanking plates. There are three double and two single entry clamps for 6/8 core 5mm OD signal cables. (See fig 2)

Feed the cable from behind the unit and push into the cable guides. Ensure that the moisture and insect blanking plates are inserted in to any unused cable clamps.



(fig 2)

BATTERY INSTALLATION

1. Remove the Opal RFX cover
2. Remove the module from the bracket
3. Remove the Fresnel lens
4. Insert 2 x AAA Alkaline batteries into the module as shown.(fig 3) Put the base of the battery in first then click the '+' in firmly.

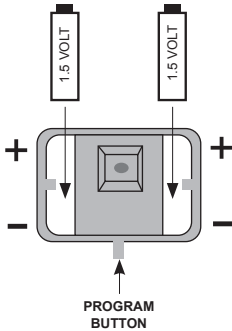

FIG 3

PROGRAM
BUTTON

To replace the batteries - push out from the holes on the reverse of the module.

SETUP

To transfer the detector code to the receiver.

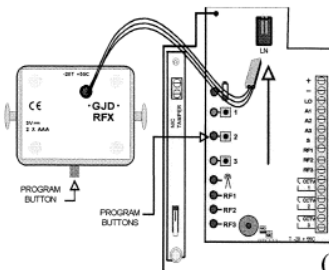

(fig 4)

1. Apply the 12VDC to the receiver.
2. Plug in the link wire from the first detector in to the receiver (see fig 4).
3. Press the respective 'Channel button' on the receiver once - the LED lights
4. Within 4 seconds press the 'Program button' on the detector once.
5. The 'Channel' indicator blinks twice. The code for that detector is stored and registered to that channel.
6. Remove the link wire from the receiver and plug into the aerial transmitter in the back of the detector (see fig 5).

Detection signals will be immediately transmitted to the receiver.

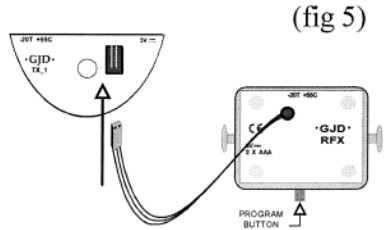

(fig 5)

Repeat steps 2 to 6 for each detector.

To check whether a code is sorted - press the channel button once - three beeps sound.

To erase a code from the receiver - press and hold down the channel button until the continuous beeps end - then release.

OPAL RFX - DETECTOR PROGRAMMING CHART

			SETTING							
			1	2	3	4	5	6	7	8
O P T I O N S	2	Range (m)	10	15	20	25	35			
	3	'S' Output Lux Level	2	5	15	30	60	120	240	24HR
	4	Pulse Count	1	2	3					
	5	Time 'CCTV' (Seconds)	0.4	1	2	4	8	25	30	60
A U X	6	Press 6 times to flash out your selected settings								
	7	Press 7 times to reset to GJD factory settings								
	8	Press 8 times and hold to start RF continuity test (see page 3)								
	9	Press 9 times and hold to generate alternative random code								

Shaded settings are factory defaults

CUSTOMISING

All factory set parameters can be changed to suit individual requirements. The highlighted areas on the programming chart show the factory settings which suit most applications. Changes can be easily made either before installation or on site. Once changes have been made they stored in a non-volatile memory.

To change any of the Opal RFX Settings:

- Press the program button for the number of the option to be changes, i.e twice for "Range", three times for "Lux Level", four times for "Pulse Count", five times for "CCTV Timer".
- Wait until the red LED goes off.
- The red LED will then flash out the existing setting.
- To change the settings for that option, press the program button the number of times for the required.
- The indicator then blinks twice and the changes are stored in the Opal RFX's non-volatile memory

EXAMPLE: To change the "Pulse Count" from 1 to 2:

- Press the program button four times
- Wait until the red LED indicator goes off
- The indicator will now flash once, indicating the current pulse count is 1.
- Press the program button twice to change the pulse count to 2.
- The indicator blinks twice and the changes are stored in the Opal RFXs non-volatile memory.

LUX 'S' OUTPUT ONLY

- (a) 2 Lux to 240 Lux = the approximate light level at which the 'S' output is activated.
 (b) 24hr = will operate day and night

All other outputs operate day and night irrespective of the 'S' output setting.

PULSE COUNT

The range of the unit will decrease if there is little difference in the temperature between the moving object and the background.

- will give a fast response
- gives better immunity with good response
- gives higher immunity to false activation

Timing 1 (2 & £≤5 seconds)

TIME 'CCTV' OUTPUT

This is the time in seconds that the 'CCTV' volt free output will activate after detection. For setup purposes the respective channel indicator will also light for this time. Adjust the jumper link on the RFX-3 Receiver to select either normally open in alarm condition or normally closed contacts.

RF CONTINUITY TEST

It is advisable to test the RF signal at the detector location prior to installation.

To enter the RF continuity test mode - press the program button on the Opal RFX 'Eight' times. One the eighth press - 'hold' the button down for 5 seconds until the LED goes out - the LED indicator will then flash and transmit one signal per seconds to the receiver. The corresponding channel indicator on the receiver will also flash once per second if there is a strong RF link established.

This test mode will automatically cancel in five minutes. Alternatively to cancel the 'RF' continuity test - press and hold the program button until the LED lights then release.

If it is necessary to conduct a site survey prior to installation of this equipment it is advisable to power the RFX-3 Receiver temporarily with a PP3 (9 volt) battery. Register one detector, then conduct and RF continuity test as detailed above. As the signals to the receiver are sent once per seconds the optimum position of both the Opal RFX and the RFX-3 Receiver can be easily established.

CHANGING THE RANDOM CODE

In the unlikely event of another radio signal affecting the correct operation of a single channel. The Opal RFX detector can generate an alternative random code. Press the program button on the Opal RFX nine times. On the ninth press 'hold' the button down for 5 seconds until the LED goes out, then release the button.

Then erase the code form the RFX-3 Receiver by holding down that 'channel button' until the beeps stop, then repeat steps '2' to '6' of the 'Setup' procedure to register the new code.

OPAL RFX INSTALLATION

During installation the electronics must be protected against water, as trapped moisture can effect or damage the unit.

1. First remove the front polythene cover by pulling forwards, then remove the lense module by pulling it out of the forked bracket.
2. Drill the wall to accept the fixing screw supplied with the wall plug.
3. Fit the housing to a secure surface. When the surface is uneven use the 4mm spacer supplied to ensure that the radio signals transmitted achieve their optimum distance.
4. Always ensure when replacing the module that it is the correct way up for the correct alignment of the beam pattern (see page 5 multibeam lens data)

TESTING OUTPUTS

(Alignment of detection beams)

The range of the detector increases without the front protective cover. Therefore the front cover must be fitted to establish the correct beam pattern alignment and when testing the outputs.

When the 'program' button is pressed momentarily the red indicator lights and pulse count '1' is automatically selected. The unit can then be aligned. The red indicator will light on the Opal RFX and the respective Channel indicator will flash every time a detection takes place. This test mode will automatically cancel five minutes after last detection. Alternatively, to cancel this 'walk test mode' press the program button twice.

ALIGNMENT

Passive infrared movement sensors detect the temperature changes of moving objects. Movement across the beams produces the best response and range whilst movement towards the detector would be less responsive. Use the pan and tilt facility to accurately target the detection zone, and adjust the range of the detector to cover the required area.

The clear mask supplied with the detector can be cut and applied vertically or horizontally to eliminate coverage of a single beam, an entire long range section or corridor beam for CCTV applications. When mounting higher than boundary fences mask off any side beams that fall outside of the required detection area. Also ensuring that no obstacles, such as walls or large trees for example, obstruct the beam pattern view.

As the unit detects a change in heat in its field of view, therefore to avoid any false alarms, direct sunshine, trees, shrubs, ponds, central heating boiler flues and animals should all be considered when sighting the detector. The unit is not recommended for mounting on metal clad buildings in direct sun as excessive heat produces haze ripple which can produce false activations.

Floodlights also emit haze ripple. When installing floodlights to provided movement activated lighting, position the floodlights at the side or above the detector. A minimum of 60cm (2 feet) is recommended, provided the detector is not in direct radiated heat from floodlight.

Once alignment is completed, check that the vent hole of the front cover is positioned at the bottom. Also ensure that both sides of the outer casing are engaged before pressing the cover firmly to securely locate it.

IMPORTANT

Ensure the detector is mounted upright on a vertical surface. If mounting the detector on a conductive or uneven surface it is advisable to use the mounting spacer provided. This will ensure that the aerial is above the 4mm clearance distance required from the surface to optimise the transmission range.

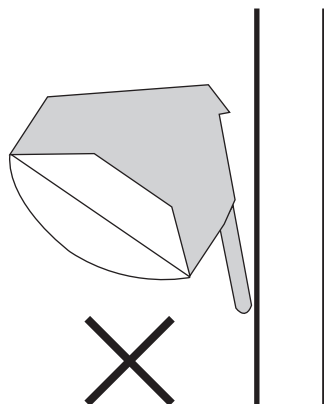
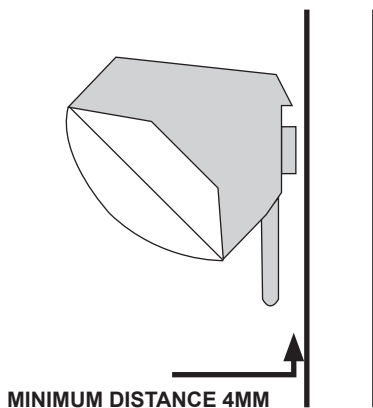

MULTIBEAM LENS DATA

The GJD multifunction lens fitted to the OPAL RFX detector produces 9 long range beams and 9 medium to short range curtain beams. Movement across the beams produces the best response and range, whilst movement towards the detector will be less responsive.

When mounting higher than boundary fences rotate the module and mask off any beams, either vertically or horizontally, that fall outside the area being covered. Use the self-adhesive clear mask supplied to the rear, smooth side, of the lens and always replace the correct way up as shown to obtain the exact beam pattern coverage.

MULTI-BEAM OPTIMUM

HEIGHT 3 METRES
 RANGE MAXIMUM
 MODULE TILT 0 DEGREE

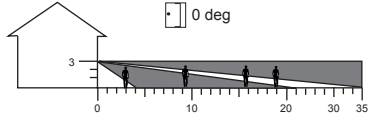
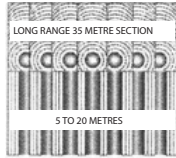

MULTI-BEAM

HEIGHT 6 METRES
 RANGE MAXIMUM
 MODULE TILT 9 DEGREE

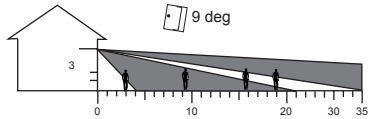
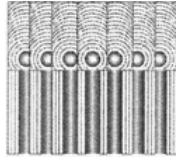

PET IMMUNITY

HEIGHT 1.5 METRES
 RANGE MAXIMUM
 MODULE TILT -2 DEGREE

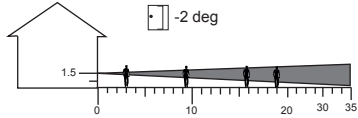
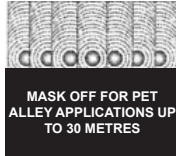

CURTAIN COVERAGE

HEIGHT 6 METRES
 RANGE MAXIMUM
 MODULE TILT 45 DEGREE

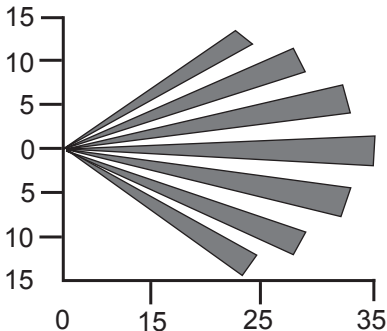
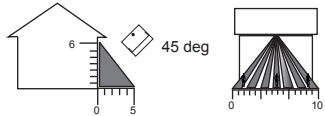

BEAM PATTERN SET TO MAXIMUM RANGE.
 MASKING TOP SECTION OF LENS WILL
 REDUCE RANGE TO 20 METRES

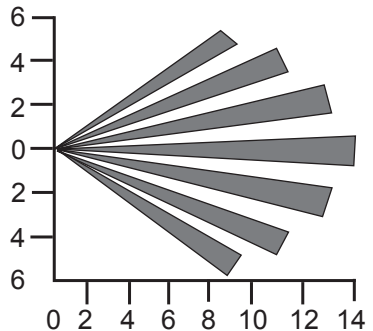

BEAM PATTERN SET TO MINIMUM RANGE.
 MASKING TOP SECTION LENS WILL
 REDUCE RANGE TO 6 METRES

OPAL RFX WIRELESS PIR (GJD018)

SUPPLY	2 x AAA Alkaline 1.5 volt (not supplied) Low power typical battery life two years
TRANSMISSION	150m line of sight: 433.92 MHz <10 mW frequency - SAW stabilised
COVERAGE RANGE	10 to 35m: 35 x 30m max. with 90° multifunction lens Internal adjustment 180° pan + 90° tilt
MOUNTING HEIGHTS	(variable) 3m high for multi-beam coverage 6m high for curtain coverage and 1.5 for pet immunity (mask supplied)
PROCESSING	Non-volatile memory: Intelligent signal processing: Digital & integral white light filter 16 million possible identification codes
ADJUSTMENTS	Detection signal (CCTV) timer 0.4 to 60 secs. Light level signal 2 Lux to daylight Pulse count 1 (2 & 3≤6 seconds)
TEMPERATURE	-20° C +55° C
DETECTOR HOUSING:	ABS high impact IP55 rated Weight - 152g Dimensions 110h x 100w x 100 deep
CERTIFICATIONS	

SIMPLIFIED EU DECLARATION OF CONFORMITY

Hereby, GJD Manufacturing Ltd declares that the radio equipment type GJD018 Opal RFX Detector is in compliance with Directive 2014/53/EU.

The full text of the EU declaration of conformity is available at the following internet address: gjd.co.uk

RFX-3 RECEIVER (GJD017)

SUPPLY	12 VDC @ 35mA nominal (9 to 20VDC maximum)
OUTPUTS (CCTV)	3 x independent channel outputs (24hr) Selectable N/O (form A) or N/C (form B) Individual timers 0.4 to 60 seconds after last detection. Non volatile memory.
OUTPUTS (A)	3 x independent switching -ve outputs (24hr) rated @ 250mA - 0.4 second on detection
RF loss of signal outputs	3 x RF/signal -ve switching rated @ 250mA
Lux OUTPUT (S)	1 x photocell controlled -ve switching Active 60 seconds after last detection
TAMPER	Back & Front tamper volt free output (form B)
INDICATION WITH OUTPUTS	Independent channel active & low battery
TEMPERATURE	-20° C +55° C
WEATHERPROOF ENCLOSURE	IP65 high impact ABS Weight - 340 grams 183 high x 123 wide x 60mm deep
CERTIFICATIONS	

SIMPLIFIED EU DECLARATION OF CONFORMITY

Hereby, GJD Manufacturing Ltd declares that the radio equipment type GJD017 RFX-3 Receiver is in compliance with Directive 2014/53/EU.

The full text of the EU declaration of conformity is available at the following internet address: gjd.co.uk

ENGINEER NOTES

w: www.gjd.co.uk ■ **t:** +44 (0) 1706 363 998 ■ **f:** +44 (0) 1706 363 991

Unit 2, Birch Business Park, Whittle Lane, Heywood, Greater Manchester, OL10 2SX, UK